

White Paper

Closed System Technology Drives the Trend Toward Safer, More Cost-Efficient Chemical Dispensing

Introduction

In dozens of industries and in millions of applications around the world, dangerous chemicals are transferred from their original shipping containers into smaller jugs or buckets or applied to other end-use processes. Historically, the predominant dispensing method in many of these applications has been through an open system where the liquid is poured out of the container. With a poured system, the container is often flipped on its side and the liquid is poured into a secondary container. The user then just carries the bucket to wherever it needs to go. A mental image of this technique quickly reveals its potential dangers and inefficiencies.



Another popular dispensing method is a semi-closed system that pumps the liquid out of a drum or container. In these systems, a dip-tube draws chemicals from vertically-oriented containers using an attachable hand or electric pump. While a step in the right direction, the semi-closed dispensing system requires a dip-tube that needs to be removed and re-inserted each time a new drum is used, exposing the end user to drips, leaks and fumes during transfer.

The primary drawback of all open and semi-closed systems is that they needlessly expose the user, equipment and the environment, to potentially hazardous chemicals and vapors.

Industry Drivers

OSHA, along with other health and safety organizations, is taking aggressive steps to minimize the risk of personnel and the environment being exposed to chemicals. These increased environmental and safety concerns are driving the trend toward disposable systems that require chemicals be transported from container to point-of-use in a closed manner. At the same time, chemical packagers and end-users - well-aware of the liabilities involved - are increasingly looking to incorporate closed systems into their chemical management solutions, both in hazardous and non-hazardous industries.

The semiconductor and life sciences industries were among the first to implement completely closed systems, not only to minimize the risk of workforce chemical exposure, but also to prevent contaminants from getting into their chemicals. With highly sensitive manufacturing processes, the presence of even the smallest amount of dirt or foreign material can prove extremely costly. A closed system allows them to control chemical purity from the point-of-origin to the point-of-use.



Example of safer chemical dispensing through a closed system:

- 1) The shipping plug is removed from the drum insert assembly;
- 2) the chemical dispensing coupler is inserted; and
- 3) the dispense system is easily closed and ready for use.

Safety Reinforcement

Another key driver is simply the high cost of open systems, including expenses related to clean up, wasted product, and accidents or injuries. For example, long-term exposure to some chemicals can cause workers to become sick, resulting in an increase in workers compensation claims. Additionally, companies might be able to reduce their insurance premiums if they can show their insurer that a closed system minimizes chemical exposure and improves overall plant safety.

For chemical and packaging industries that need to transfer, protect and use hazardous materials in their manufacturing processes, a closed system is the safest and presents the least risk of exposure. Moreover, in the case of a non-hazardous food application, a closed system can help prevent oxidation of food products and extend product shelf life.

There also are intangible benefits to a closed system, such as a cleaner work environment. Many plants can tolerate an unsightly work environment with frequent drips and spills on the floor caused by chemicals being transferred in buckets. In instances where cleanliness is a major concern however, a closed system can help contain fluids, resulting in a cleaner, less contaminated workplace.

While the applications for closed systems vary widely - from benign materials, such as olive oil, to highly dangerous liquids, such as sulfuric acid - the overall objective is the same: to enclose the product and to protect it against oxygen and particle contamination while protecting the environment and personnel who must handle the containers. This includes minimizing or completely eliminating the potential for chemical or vapor exposure at the point of connection, during dispensing and when the container is disconnected.

In many semi-closed, top-dispensing systems, the biggest source of chemical exposure is from the constant reuse of the "stinger" type dip-tube, which exposes the user to drips, leaks and fumes during transfer. The best way to minimize this exposure is to limit the need to remove the dip-tube from the drum. This is accomplished with containers that have an integrated dip-tube based dispensing system that includes a common bung closure, a disposable dip-tube and a reusable quick disconnect coupler. This ensures that both ends of the dispensing system are sealed from point-of-origin to point-of-use. To dispense the chemical, the user simply removes a shipping plug and then connects the coupler. The end user doesn't have to worry about moving dip-tubes in and out of drums or opening the container in any significant way.

Fully closed systems also have additional safety mechanisms, such as a ported vent system, which allows air into the system to speed chemical flow and safely manage venting without releasing vapors. The vapors can either be routed to atmosphere by using a check valve to prevent harmful vapors from contaminating the work environment while allowing make-up air in, or it can be connected to a pressure source to force liquid out of the container. It can

even be connected to an inert blanket gas source (N₂, CO₂, etc.) to protect sensitive liquids such as edible oils, fragrances or other chemicals from oxidation resulting from contact with air.

This type of integrated system eliminates the need to install, remove or clean a dip-tube, minimizing the potential for fluid or vapor contact while allowing fast container changeovers. Moreover, because the dip-tube can be disposed along with the drum after use, the chemical remains benign to the end-user.

Safety Meets Efficiency

Where previously the cost of such integrated closed systems could only be justified by large facilities, today's newer technology also offers advantages for smaller end-user applications. These systems provide more user-friendly features for companies looking to better control costs while maintaining cleaner performance and greater worker safety.

These systems offer users a number of cost-saving advantages and are ideally suited to cost-sensitive, one-way container applications. For example, the dip-tube is designed for single use and can be incorporated into the cost of the drum without significantly adding to the unit cost, while the coupler can be reused thousands of times. In addition, post-use handling, clean-up and disposal of the drum is much more straightforward because the low-cost drum insert and closure are recyclable right along with the drum. For high-volume users, cost savings and return on investment are realized very quickly.

Any open system can be converted to a closed system using integrated dip-tube based technology, such as the DrumQuik® PRO from Colder Products Company. It is ideal for high volume, single-use applications as well as for smaller end-user systems. The drum insert assembly is made from virgin natural polyethylene material so it can be easily recycled with the drum. The coupler is made from superior polypropylene to assure long-term chemical resistance with most general and high purity uses.

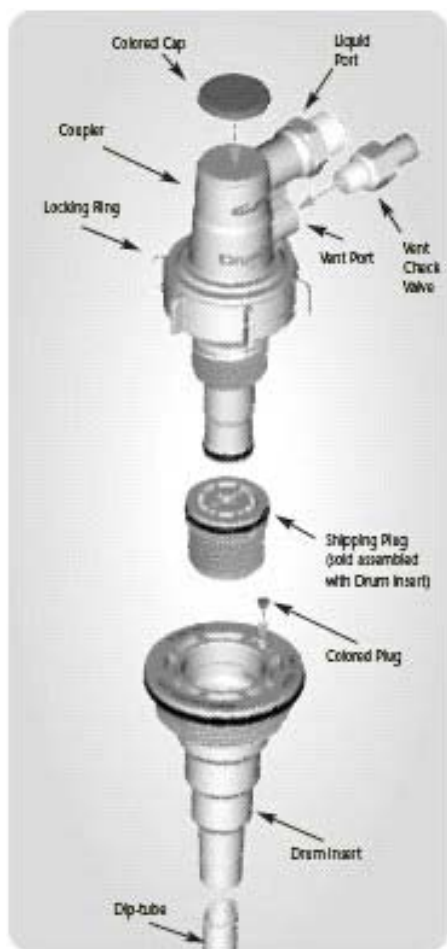

Core benefits of an integrated closed system include:

- Increased productivity by cutting down on clean-up time
- Reduced liability risk and cost
- Improved worker safety due to minimized exposure
- Reduced environmental contamination
- Less product waste
- Easy setup and operation
- Reduced oxidation of food products
- Support of cost sensitive one-way and single-trip packaging
- Elimination of return shipping costs

Closed System Considerations

The first priority in considering your need for a closed system is always the safety of people. In other words, is anyone's health being affected by the chemicals you're using or their contact with them? If the answer is yes, then you should immediately begin implementing a plan to minimize this exposure.

A secondary consideration is the potential for incorrectly mixing incompatible chemicals, resulting in wasted product, or worse, the destruction of an entire facility. Depending on the application and the environment, the ability to prevent misconnections or accidental blending of incompatible chemicals is critical. If this is a potential concern, a closed system with integrated color and/or mechanical keying is an important option to consider.

Additional operational and safety benefits can be realized with innovative RFID technology, such as Colder's patented IdentiQuik® RFID system, which can be incorporated into the dispensing system. With these systems, before the final connection of the body and insert is made, the RFID system automatically exchanges product data to help prevent misconnections. Manufacturers can use this feature to ensure brand integrity, improve quality control and automatically calibrate dispensing equipment for the fluid being dispensed.

Evaluation of the entire closed system, not only the drum connection, is recommended. The connection at the process end of the line should also be taken into consideration. Typically this is a piece of equipment or some end-user process that also requires a safe, reliable connection. This is where non-spill quick-disconnect couplings can play a key role by providing an easy-to-use connection. This is an important, but often overlooked part of a safe, reliable closed system design.

When considering an integrated closed system, compatibility is a critical component. Select a system that is compatible with many types of common drums and containers. Depending on your application requirements, it should also be capable of passing United Nations and U.S. Department of Transportation approval standards for the transport of HAZMAT grade chemicals. If food or other consumable products are being dispensed, then the system needs to be constructed of FDA-approved materials.

Until end users begin to re-think their chemical dispensing philosophy, or come under a clear mandate from regulatory authorities, open systems will continue to be employed. Still, with the ever-increasing desire to minimize chemical exposure, closed system delivery with an integrated dip-tube design offers efficiency and safety benefits that clearly establishes it as a best practices approach.



CASE STUDIES:

From Fragrances to Fertilizers

One industry where a closed system can provide significant cost savings is in fragrance manufacturing. A typical fragrance factory might house a thousand or more raw ingredients stored in individual containers in huge warehouses. Whenever a new batch of product needs to be produced, plant personnel have to pull the right drums out of storage and place them onto a staging skid.

The skid is then moved into the mixing room where a specific amount of ingredient from each drum is extracted and weighed. The ingredients are then blended in a mixing vat. When finished, workers must move all these raw ingredient containers back to the warehouse. This transporting and dispensing of each container consumes a significant amount of time and effort.



Why Use DrumQuik® PRO?

- ◆ **Safety:** Minimize spills, fumes and environmental impact
- ◆ **Performance:** High flow capacity
- ◆ **Easy:** Intuitive locking ring design for quick connection
- ◆ **Durability:** Built to withstand harsh operating conditions
- ◆ **FDA Materials:** Suitable for transfer of food products
- ◆ **Vapor Management:** Ported vent allows control of fumes, blanket gas connection or pressure dispensing
- ◆ **Economic:** Low cost for high volume, single-trip containers
- ◆ **Recyclable Materials:** Allow easy disposal with containers

A more effective approach would be to install a line to every container as part of an integrated closed dispensing system. The containers would be connected via a quick-disconnect system to keep it closed and a programmable controller would be used to remember every single recipe. The result would be a process similar to the one you encounter when purchasing a can of paint at your local hardware store.

When you buy a can of paint, you view a paint selection guide that includes maybe a thousand color choices. You then pick out a card and identify the color that you want. The sales person brings it over to the mixing area and enters the color code number, which corresponds to the specific paint recipe pre-programmed into a computer. The machine then dispenses X amount of blue, X amount of red, and X amount of yellow into a white base. The paint is then mixed and your product is ready to go.

The labor savings and throughput improvements with this automated, closed system approach are significant, which are not only critical in fragrance production, but in virtually every other industry as well.

Another pressing concern in many industries is the cost and logistics involved with cleaning and preparing drums for reuse. Case in point is the fertilizer manufacturing industry. Many of these manufacturers produce very aggressive pesticides and herbicides. Historically, they've been required to invest in their own fleet of very expensive stainless steel containers and dip-tubes. Because of the high cost, they can't afford to make them disposable.

Once their end user customers have emptied the drums, they then must be shipped back to the manufacturer for cleaning and refilling. The freight expense involved with this process is huge, not to mention the labor and logistics involved with handling and managing a dedicated fleet of drums. Plus, the cost to have these drums and dip-tubes cleaned and reconditioned can be as high as \$2 per gallon, or \$110 per drum.

When you compare this reusable approach with the cost of a disposable dip-tube, which can be as low as a few dollars, the cost-savings potential is clear. Therefore, the solution in this case is to move away from the dedicated drum approach and toward a single-use system. Single-use containment packaging eliminates extensive investment in the fleet of drums and removes the costly and complex logistical support requirements.

For more information, contact Rich Herpers
email: info@colder.com
phone: 651-645-0091